



- Self-limiting characteristic
- Random mounting position
- Extremely flat design
- ATEX gas and dust application approval
- Wide rated voltage range
- Large, black, anodized convector surface

The extremely flat BARTEC HSF heater plates are mainly used in potentially explosive areas for applications, which require the maintenance of a specific temperature. The use of these heater plates guarantees a maximum degree of operational safety, as temperature fluctuations can be efficiently avoided and, yet, the required minimum temperatures can be maintained. The heater plates reliably protect electrical installations against function failures due to creepage currents and also offer protection against other failures caused by corrosion formation at mechanical system components. The radiators are ready for connection and they are maintenance-free. The application areas of these heaters comprise switch and control cabinets, transmitter protection boxes, measuring equipment, analyzer cabinets for sample preparation, and many more.

**Construction**

The HSF heater plates are based on a PTC (positive temperature coefficient) heating element. The special design of the aluminum profile facilitates an even temperature distribution in the interior of housings and cabinets. For an optimum free convection, the fins should not be covered.

**Function**

The PTC heating elements increase their electrical resistance as the temperatures rises. A high resistance results in a low heating output. At high temperatures, the heating capacity is reduced to a minimum heating output, which ensures that the limit temperature of the respective temperature class cannot be exceeded. Moreover, these heating elements regulate their resistance in dependence of the voltage. Therefore, the HSF heating plates can be applied in a wide supply voltage range. Should you require further information on the detailed layout of the heating capacity in holding temperature applications, please contact us.

**Explosion protection**

Marking	Ⓔ II 2G Ex db IIC T4, T3 Ⓔ II 2D Ex tb IIC T135 °C/T200 °C
Certification	PTB 03 ATEX 1221 X
Other approvals and certificates, see <a href="http://www.bartec.de">www.bartec.de</a>	

**Technical data**

Protection class	IP 68, NEMA 4X
Application temperature range	-50 °C to +180 °C
Ambient temperature range	-50 °C to +60 °C
Rated voltage	AC/DC 120 to 240 V
Nominal power	50, 100, 120, 200 and 300 W (at 0 °C application temperature)
Connection	Hose line EWKF 3 x 1.5 mm <sup>2</sup> ; Ø 8.1 mm
Mounting position	random
Material	black, anodized aluminum, resistant to sea water

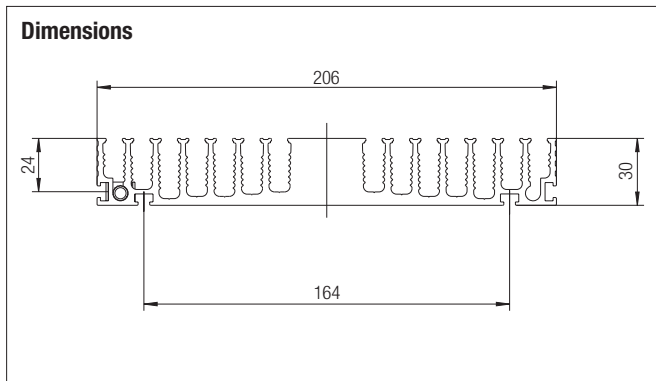

**Ordering information**

Designation	Nominal power	Cable length	Weight (netto)	Dimensions in mm (L x W x H)	Temperature class	Order no.
HSF 50 T4-1	50 W	1 m	0.9 kg	105 x 206 x 30	T4	<b>27-2C54-7054110Z1000</b>
HSF 50-T4-5	50 W	5 m	1.3 kg	105 x 206 x 30	T4	<b>27-2C54-7054110Z5000</b>
HSF 100-T3-1	100 W	1 m	0.9 kg	105 x 206 x 30	T3	<b>27-2A53-7104110Z1000</b>
HSF 100-T3-5	100 W	5 m	1.3 kg	105 x 206 x 30	T3	<b>27-2A53-7104110Z5000</b>
HSF 120-T4-1	120 W	1 m	1.8 kg	225 x 206 x 30	T4	<b>27-2B54-7124150Z1000</b>
HSF 120-T4-5	120 W	5 m	2.2 kg	225 x 206 x 30	T4	<b>27-2B54-7124150Z5000</b>
HSF 200-T3-1	200 W	1 m	1.8 kg	225 x 206 x 30	T3	<b>27-2B53-7204150Z1000</b>
HSF 200-T3-5	200 W	5 m	2.2 kg	225 x 206 x 30	T3	<b>27-2B53-7204150Z5000</b>
HSF 300-T3-1	300 W	1 m	2.5 kg	325 x 206 x 30	T3	<b>27-2J53-7304170Z1000</b>
HSF 300-T3-5	300 W	5 m	2.9 kg	325 x 206 x 30	T3	<b>27-2J53-7304170Z5000</b>

Technical data subject to change without notice.